

- Double shear load cell
 - 3000 divisions O.I.M.L. R60 class C
 - Measuring element from Stainless Steel
 - Hermetically sealed, fully welded
 - Protected IP 68 (EN 60529)
 - Easy installation
 - Available in **ATEX** version (optional)
Zone 0-1-2 (gas) and 20-21-22 (dust)
 - Mounting Kit available in version certified according EN1090 (optional)
 - Application: Tanks and silos weighing systems with highly linear and low profile requirements
- Doppelscherstab-Wägezelle
 - 3000 Teile O.I.M.L. R60 Klasse C
 - Messelement aus Edelstahl
 - Hermetisch dicht verschweißt
 - Schutzart IP 68 (EN 60529)
 - Einfache Montage
 - Erhältlich in **ATEX** -Ausführung (optional)
Zone 0-1-2 (Gas) und 20-21-22 (Staub)
 - Lastecke erhältlich in zertifizierte EN1090-Ausführung (optional)
 - Anwendungen: Behälter- und Silowaagen mit hoher Linearität und niedriger Bauform

Model Modell	Nominal capacity Nennlast Ln	Accuracy class Genauigkeitsklasse n. OIML	Minimum division Kleinster Teilungswert vmin	Minimum load Minimumlast 0 % Ln	Service load Gebrauchslast 150 % Ln	Safe load limit Grenzlast 200 % Ln
460 5 t	5 t	3000	0.5 kg	0 kg	7.5 t	10 t
460 10 t	10 t	3000	1 kg	0 kg	15 t	20 t
460 20 t	20 t	3000	2 kg	0 kg	30 t	40 t
460 30 t	30 t	3000	3 kg	0 kg	45 t	60 t
460 50 t	50 t	3000	5 kg	0 kg	75 t	100 t
460 75 t	75 t	3000	7.5 kg	0 kg	112.5 t	150 t
460 100 t	100 t	3000	10 kg	0 kg	150 t	200 t

MODEL 460

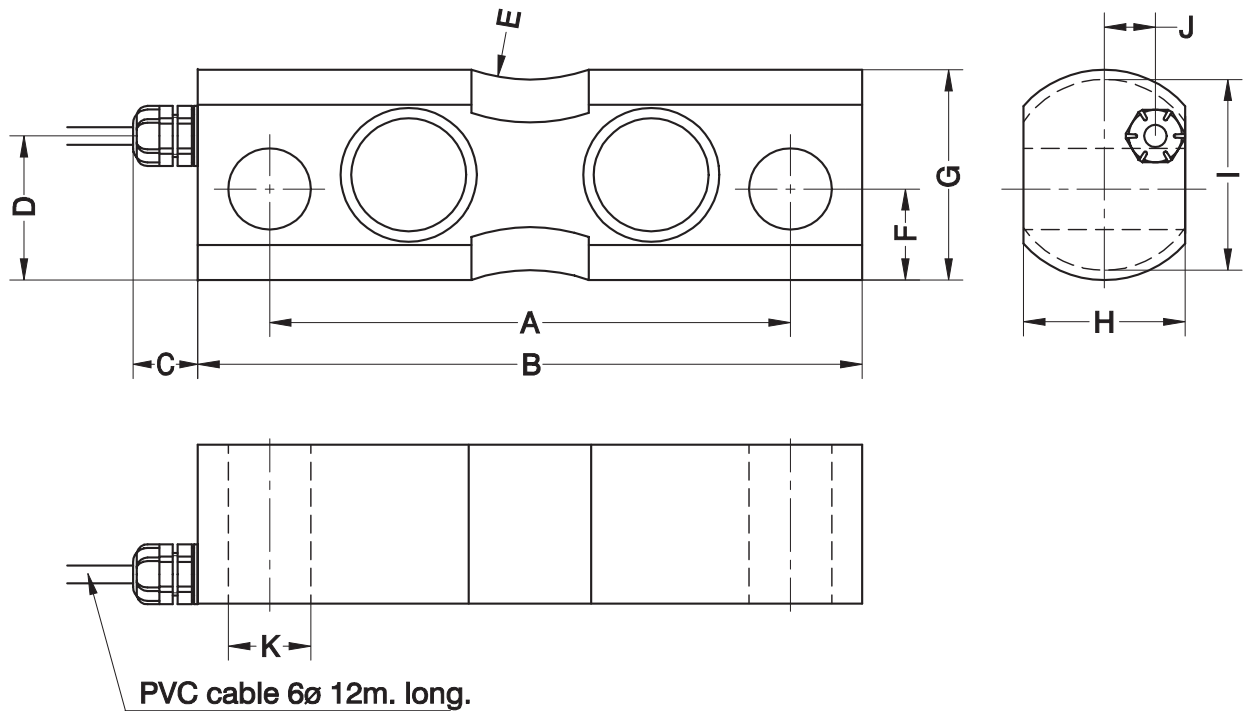

Nominal Load Nennlast	A	B	C	D	E	F	Gø	H	Iø	J	Kø	Transport weight Transportgewicht
5...20 t	145	185	16	41	r.50	25.7	59.5	45	55	14	23	3.2 kg
30...50 t	220	285	16	48	r.50	29.7	74.5	60	66	22	30	8.6 kg
75...100 t	260	340	16	66	r.50	37.2	99.5	80	91	32	50	16.2 kg

Dimensions in mm. Abmessungen in mm.

SPECIFICATIONS			TECHNISCHE DATEN
Nominal capacities (Ln)	5-10-20-30 50-75-100	t	Nennlasten (Ln)
Accuracy class	3000	n. OIML	Genauigkeitsklasse
Minimum dead load	0	%Ln	Minimale Vorlast
Service load	150	%Ln	Gebrauchslast
Safe load limit	200	%Ln	Grenzlast
Total error	< ±0.017	%Sn	Zusammengesetzter Fehler
Repeatability error	< ±0.015	%Sn	Wiederholgenauigkeit
Temperature effect: on zero	< ±0.01	%Sn/5 °C	Temperaturfehler: Nullpunkt
on sensitivity	< ±0.006	%Sn/5 °C	Kennwert
Creep error (30 minutes)	< ±0.016	%Sn	Kriechfehler (30 min)
Temperature compensation	-10...+40	°C	Nenntemperaturbereich
Temperature limits	-30...+70	°C	Arbeitstemperaturbereich
Nominal sensitivity (Sn)	2 ±0.1%	mV/V	Nennkennwert (Sn)
Nominal input voltage	10	V	Nom. Speisespannung
Maximum input voltage	15	V	Max. Speisespannung
Input impedance	800 ±30	Ω	Eingangswiderstand
Output impedance	700 ±5	Ω	Ausgangswiderstand
No load output	±2	%Sn	Nullsignaltoleranz
Insulation resistance	> 5000	MΩ	Isolationswiderstand
Maximum deflection (at Ln)	0.6-1	mm	Nennmessweg (bei Ln)

ELECTRICAL CONNECTION ELEKTRISCHER ANSCHLUSS:

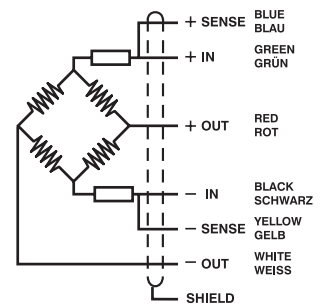

«SENSES»: 2 additional wires to maintain a constant voltage supply at the load cell when used with proper instrumentation. Use specially when long wires and wide temperature range.

SHIELD: Not connected to transducer body.

"SENSE-Leitung": zwei zusätzliche Adern, um eine konstante Spannungsversorgung an der Wägezelle zu gewährleisten, wenn entsprechende Elektronik verwendet wird. Speziell bei langen Leitungen und grossem Temperaturunterschied auf der Leitung.

SCHIRM: nicht am Wägezellenkörper angeschlossen.

MOUNTING KIT LIFT-OFF PREVENTION FOR SILO FOR 460 LASTECKE MIT ABHEBESICHERUNG FÜR 460

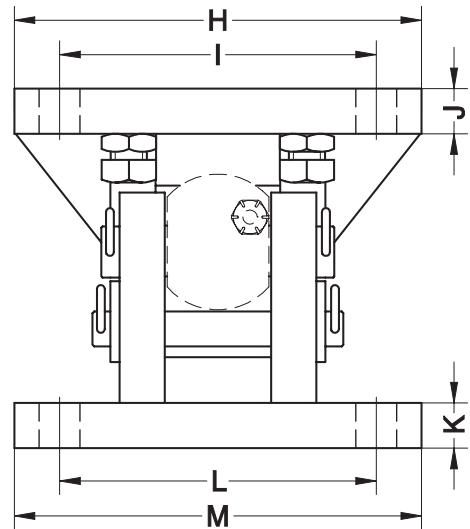
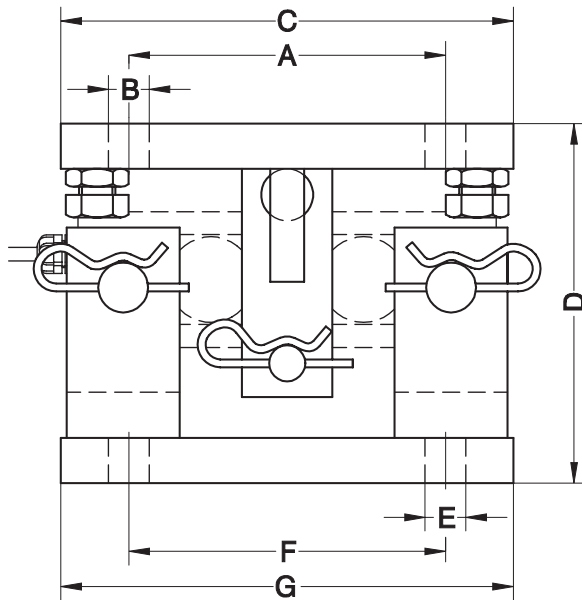
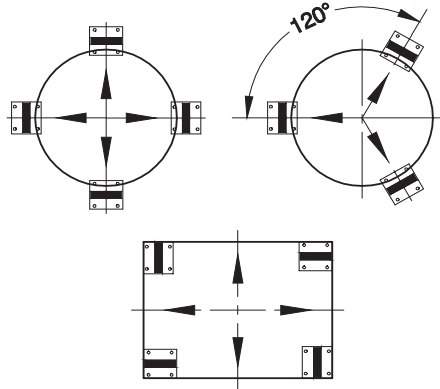

Nominal Load Nennlast	A	B \emptyset	C	D	E \emptyset	F	G	H	I	J	K	L	M	Transport weight Transportgewicht
5...20 t	140	18	200	160	18	140	200	180	140	20	20	140	180	17 kg
30...50 t	175	22	300	200	22	175	300	220	175	25	25	175	220	39 kg
75...100 t	220	26	370	270	26	220	370	300	220	30	30	220	300	82 kg

	Steel alloy zinc-plated / <i>Verzinkter Stahl</i>			Stainless Steel / <i>Edelstahl</i>		
	5...20 t	30...50 t	75...100 t	5...20 t	30...50 t	75...100 t
Max. permissible side load offset transverse to load cell <i>Max. Verschiebung in Querrichtung</i>	±5 mm	±5 mm	±10 mm	±5 mm	±5 mm	±10 mm
Maximum lift-off force <i>Max. Zugkraft vertical</i>	62.7 kN	101 kN	206.9 kN	78.4 kN	127.5 kN	228.5 kN
Maximum force transverse to load cell <i>Max. Kraft in Querrichtung</i>	41.2 kN	68.6 kN	116.7 kN	35.3 kN	52.9 kN	107.8 kN
Maximum force longitudinal to load cell <i>Max. Kraft in Längsrichtung</i>	92.2 kN	143.2 kN	151 kN	70.6 kN	141.2 kN	180.4 kN

Dimensions in mm. *Abmessungen in mm.*