

HIGH CAPACITY LOAD CELL ASSEMBLY FOR SILO AND TANK WEIGHING

capacities 100t - 600t



A stainless steel compression load cell housed in an integral mounting assembly, which is ideal for general commercial weighing of large tanks, silos and vessels, particularly in the cement, minerals and coal industries. The design ensures optimum performance and eliminates many traditional problems encountered during the installation of high capacity weighing systems. The T30 load cell and mounting assembly are supplied as a complete locked unit, ready to install.

The special mounting assembly design readily accommodates structural mis-alignment and horizontal movement due to thermal expansion and contraction of the structure. Lift off protection is built into the design and can withstand forces of up to 20% of the load cell capacity, making the unit ideal for exposed installations subject to strong winds.

- Alloy steel load sensor
- Construction sealed to IP67
- Self-aligning weighing assembly
- Waterproof cable connector
- Simple low cost installation
- Tough epoxy painted mounting assembly
- High accuracy
- Thermal expansion compensation
- Integral lift off prevention
- 5 year warranty

T30

technical specification...

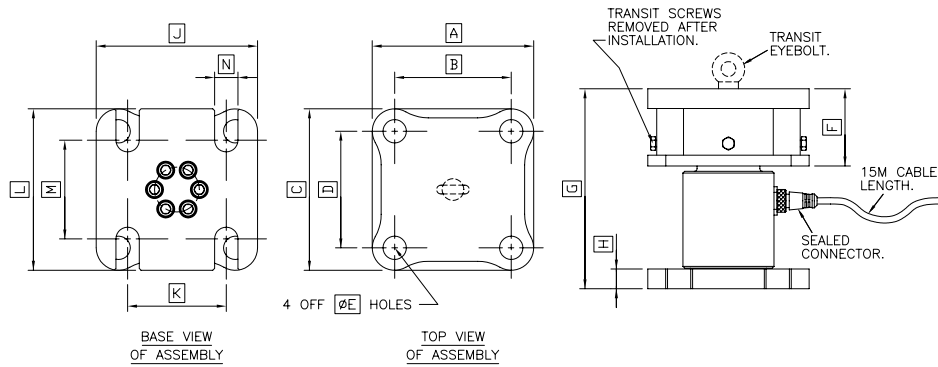

T30 Load Cell

	Load cell specification	Units
Load Cell Capacities	100, 200, 300, 400, 600	t
Rated Output	2.0 +/- 0.25%	mV/V
Combined error	< +/- 0.01	%*
Non-repeatability	< +/- 0.03	%*
Creep (30 minutes)	< +/- 0.05	%*
Temperature Effect on Zero Balance	< +/- 0.003	%* / °C
Temperature Effect on Span	< +/- 0.005	%* / °C
Compensated Temperature Range	-10 to +40	°C
Operating Temperature Range	-40 to +80	°C
Safe Overload	150	%*
Ultimate Overload	300	%*
Zero Balance	< +/- 2	%*
Input Resistance	750 +/- 30	Ω
Output Resistance	700 +/- 1.5	Ω
Insulation Resistance	> 500	MΩ @100v DC
Recommended Supply Voltage	10	V
Maximum Supply Voltage	15	V
Cable Length	15	m
Cable Material	PVC	
Nominal Shipping Weight	T30-100t	23 kg
	T30-200t	66 kg
	T30-300t, 400t, 600t	105 kg
Protection Class	IP67	

*All percentages are related to Rated output

T30 Mounting Assembly

Mounting Assembly	Load Cell Capacity (t)	Maximum Lift Off (kg)	Maximum Side Load (kg)	Maximum Angular Mis-alignment (°)
T30 - 100T	100	20,000	15,000	+/- 4
T30 - 200T	200	40,000	30,000	+/- 4
T30 - 300T	300	120,000	90,000	+/- 4
T30 - 400T	400			
T30 - 600T	600			

Dimensions

Capacity (t)	100	200	300 400 600
A	180	240	270
B	130	180	210
C	180	240	270
D	130	180	210
E	26	32	32
F	86	112	135
G	223	305	370
H	22	32	38
J	180	240	270
K	110	150	170
L	180	240	270
M	110	150	170
N	26	32	32

All dimensions are in mm

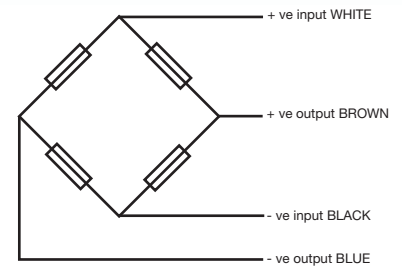

Electrical Connections

Via 4 wire, 7.4mm diameter, screened with integral 4-way connector.

DISTRIBUTED BY:

SVENSKA VÅG AB

Svenska Våg AB
Sjöddevägen 5
352 46 Växjö
Tel. 0470/724060
Mail: info@svenskavag.se / www.svenskavag.se

THAMES SIDE SENSORS LTD

Unit 10, io Trade Centre, Deacon Way, Reading, Berkshire RG30 6AZ

tel: +44 (0) 118 941 1387
fax: +44 (0) 118 941 2004

sales@thames-side.co.uk
www.thames-side.com



Issue: T30.07.13

Our policy is one of continuous product enhancement. We therefore reserve the right to incorporate technical modifications without prior notification.